

Year 6 Science – Summer 1– *Electricity*

What I should already know

How a simple electric circuit works

- electricity is a form of energy.
- a source of electricity (mains or battery) is needed for electrical devices to work.
- electricity sources push electricity round a circuit.
- understand a complete circuit is needed for electricity to flow and devices to work.
- understand that some materials allow electricity to flow easily and these are called conductors.
- materials that don't allow electricity to flow easily are called insulators.

What I will know by the end of the unit

To know and understand that the amount of voltage in a circuit can affect the output of a component inc brightness, volume and speed.

- To know that batteries/cells are a store of energy and this energy pushes electricity around the circuit.
- To know that battery/cell energy is measured in voltage.
- To understand that when the battery's/cell's energy is gone it stops pushing. (Voltage measures the 'push.')
- To know the symbols for: lamp, wire, buzzer, cell, battery, motor, switch (open), switch (closed).
- To understand that a series circuit will not work if a lamp is broken or a wire is disconnected.
- To understand how to vary the output of a component e.g. bulb, buzzer, motor

Turning a switch off (open) breaks a circuit so the circuit is not complete and electricity cannot flow. Any bulbs, motors or buzzers will then turn off as well.

Adding more bulbs to a circuit will make each bulb less bright. Using more motors or buzzers, each motor will spin more slowly and each buzzer will be quieter.

Adding more cells to a complete circuit will make a bulb brighter, a motor spin faster or a buzzer make a louder sound.

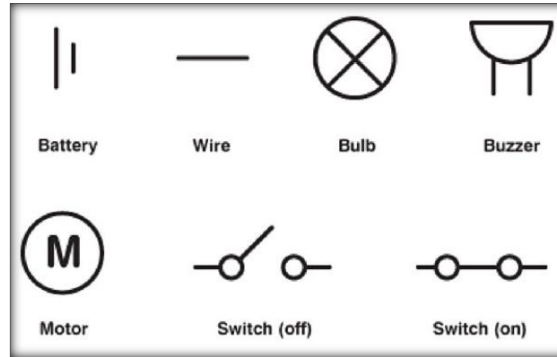

Draw the circuit symbols first. Use a ruler to draw all the wires as straight lines and do not let the wires cross each other.

Circuit Diagrams

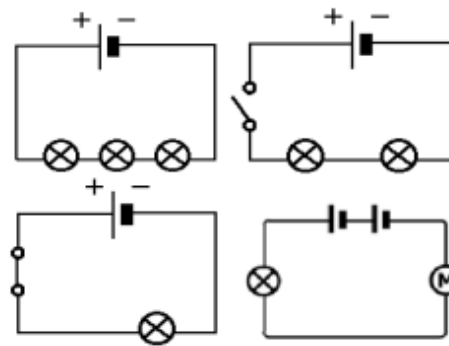

Key Vocabulary

electricity	a form of energy caused by electrons moving
electrons	very small particles that travel around an electrical circuit.
circuit	a path that an electrical current can flow around
current	the flow of electrons, measured in amps.
circuit diagram	a visual representation of a circuit
circuit symbol	a visual picture/icon that stands for something else
component	a part used in an electrical circuit
cell	A device that stores chemical energy until it is needed. A cell is a single unit.
battery	a battery is a collection of cells.
bulb	a component that turns electrical energy to light and heat energy by passing an electrical current through a filament
buzzer	a component that turns electrical energy to sound energy
motor	a component that turns electrical energy into movement
switch	a switch turns an electrical circuit on or off by completing or breaking the circuit
voltage	the force that makes the electric current move through the wires. The greater the voltage, the more current will flow.

- 1.) If you make the wires longer, the bulb will get dimmer. This is because there is more resistance.
- 2.) If you add more bulbs, the bulbs get dimmer. This is because there is also more resistance.
- 3.) If you add more cells, the bulbs will get brighter. This is because there is less resistance and a greater current.

